



**EXPLOSION PROOF ELECTRICAL CONTROL FIRE MONITOR**

**PSKD20Ex-BS    PSKD30Ex-BS**

**QUANZHOU FOREDE FIREFIGHTING EQUIPMENT CO.,LTD**

[www.forede.com](http://www.forede.com)

Copyright@2020(forede)

## **TABLE OF CONTENTS**

PRODUCT SAFETY INFORMATION.....	03
MONITOR DESCRIPTION.....	04
COMPONENT LIST.....	05
SYSTEM WIRING.....	06
INSTALLATION.....	07
OPERATION INTRODUCTION.....	09
FIRE MONITOR PARAMETERS.....	11
OUTLINE DIMENSION.....	12
MOVEMENT ANGLE.....	12

## **PRODUCT SAFETY INFORMATION**

- All personnel who may be expected to operate this equipment must be thoroughly trained in its safe and proper use.
- Before flowing water from this device, check that all personnel (fire service and civilian) are clear of the stream path. Also confirm stream direction will not cause avoidable property damage.
- Become thoroughly familiar with the hydraulic characteristics of this equipment, as well as the pumping system used to supply it.
- Whenever possible, this equipment should be operated from remote location to avoid exposing personnel to dangerous fire conditions.
- Always open and close valves slowly to avoid water hammer.
- After each use, and on a scheduled basis, inspect equipment per instructions in the maintenance section.
- Keep fingers and hands clear of moving parts.
- Disconnect power before servicing and electric valve or electric valve controller.
- Any modifications to the electrical will destroy the IP-66 rating and void warranty coverage of the enclosure and all components within.

### **! Warning**

Do not attempt to disconnect or work on any electrical equipment in this system unless power is removed or the area is known to be non-hazardous.

### **! Important**

Before installing and operating this equipment, read this manual thoroughly.  
Proper installation is essential to safe operation.

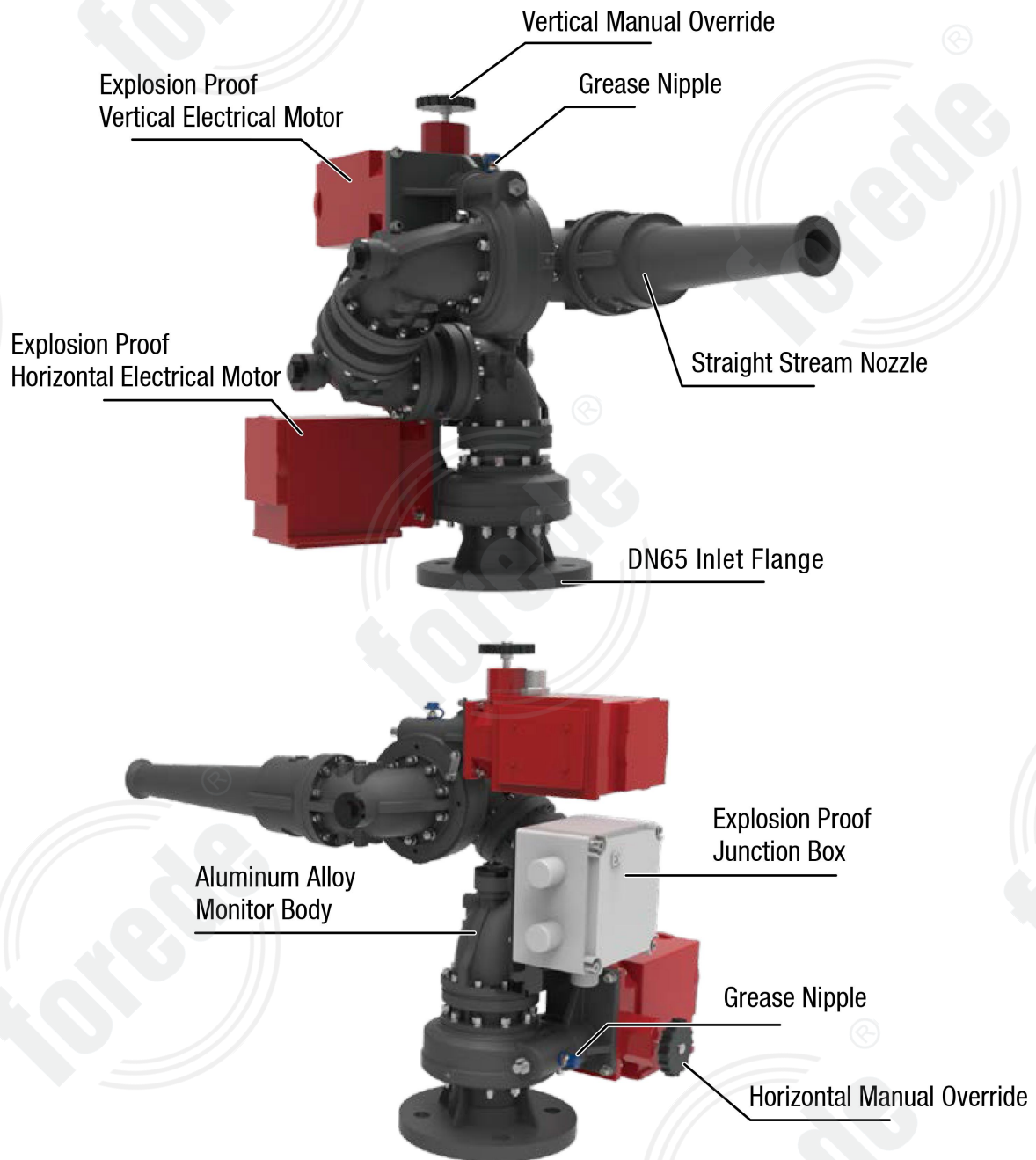

## **MONITOR DESCRIPTION**

Explosion Proof Electrical Control Monitor constitute as below:



## COMPONENT LIST

NAME	Explosion Proof Monitor Body (Standard)	Straight Stream Nozzle (Standard)
IMAGE		
MODEL NO.	PSZC-65B (EX)	
DESCRIPTION	2.5 inch waterway	PTZC-Z-20B 1200 LPM
	DC 24V Electrical motor Explosion Proof Class Exde II CT4GB	PTZC-Z-30B 1800 LPM (Optional)
	SS304 Worm, Aluminium Gear	Working Pressure:8 bar
	2.5 inch/DN65 Inlet flange	2.5 inch NH inlet
NAME	Explosion Proof Control Box (Standard)	RC Transmitter (Standard)
IMAGE		
MODEL NO.	BX1-23-GC	CTRL - RCT01
DESCRIPTION	Standard Control Box for Industrial Use	Max. 150 meters RC Distance
	Explosion Proof Class Exde II CT4GB	IP65 Standard Sealed

NAME	Explosion Proof Electrical Valve (Optional)	Centralized Control Cabinet (Optional)
IMAGE		
MODEL NO.	DDF(EX)-SX	JZKZ-SX
DESCRIPTION	DC 24V	Standard Piano Platform Cabinet
	2.5 inch / DN65	Remote centralized control
	Rating Power 15W	C/W Explosion Proof Camera, available for video playback

## **SYSTEM WIRING**

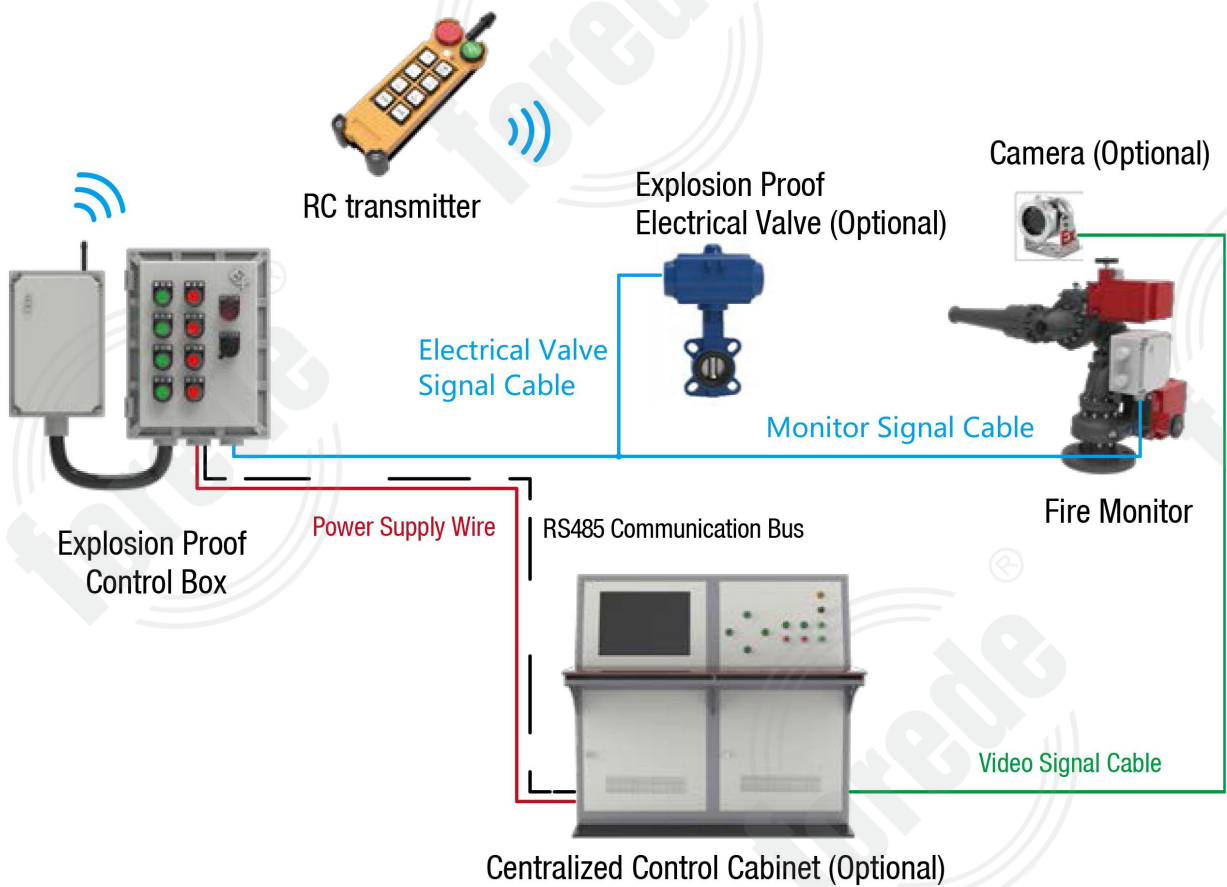

## **INSTALLATION**

### **! Warning**

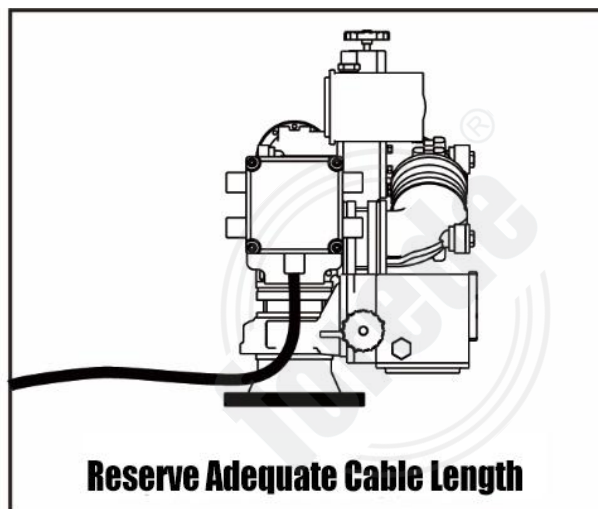
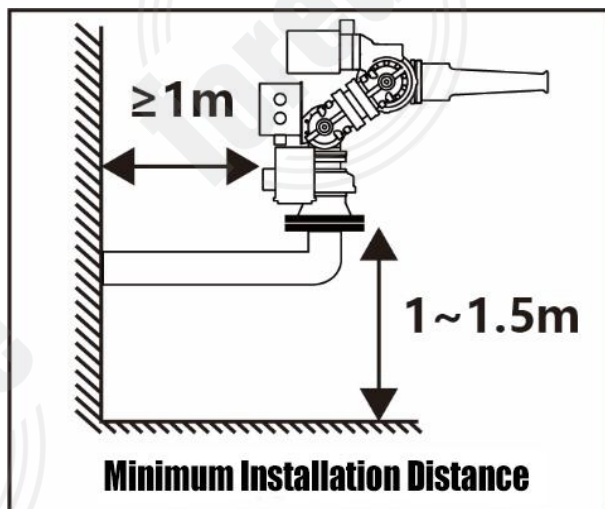

- There shall be no obstacles within the radius of 1 meters around the fire monitor, so as not to affect the rotation of the fire monitor; Keep a distance 1~1.5 meters from the fire monitor inlet flange to the under platform, so as not to affect the jetting range of the fire monitor.
- In order to ensure the normal rotation of the fire monitor, before install the fire monitor, the wire harness of the fire monitor must be reserved with a certain length, so as to prevent the fire monitor from being strangled and unable to rotate normally due to the short wire harness.
- Shut off power supply before installation and maintenance.

### **! Important**

- During installing, the load-bearing capacity of the installation pipe should be considered, the support of the installation pipe should not be less than two in two directions, the support frame should not be less than two.
- The fire monitor should be installed after the pipeline installation, washing and pressure test.
- The fire monitor should be properly kept before installation, and corresponding measures should be taken to prevent dust, moisture and corrosion.
- The pipe connected with the fire monitor flange should be vertically upward to ensure that the nozzle of the fire monitor is horizontal after installation.
- The pipe flange plane connected with the fire monitor flange should be horizontal to prevent inclination.
- Handle with care, avoid Collision.

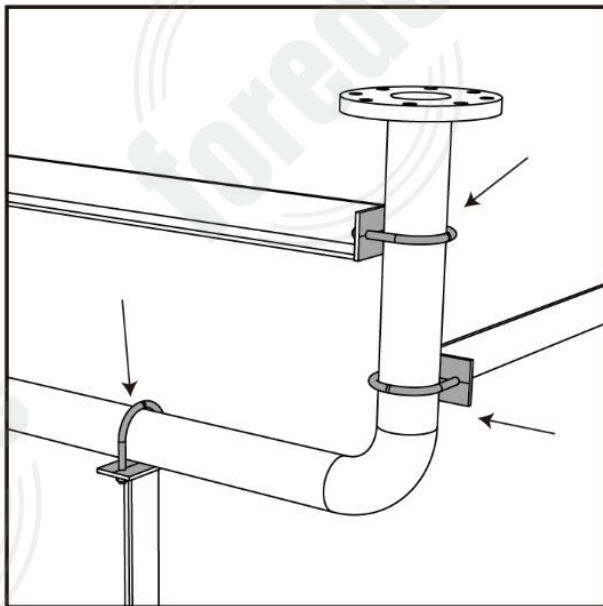

1, The installation of fixed support. The image is for reference only, please install the fixed support according to the actual situation of the area where the fire monitor is installed.

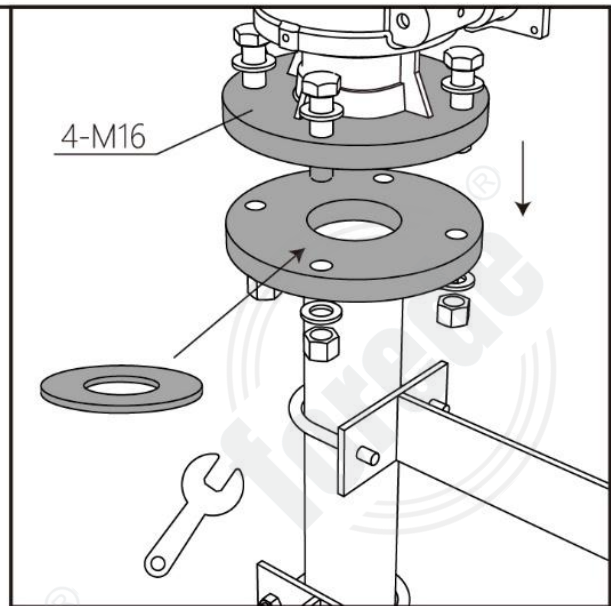

2, Place the sealing gasket between the flange; after aligning the mounting hole, insert the M16 bolt (with metal gasket), place the metal gasket at the other side and fix the nut, cross install the other 3 bolts.

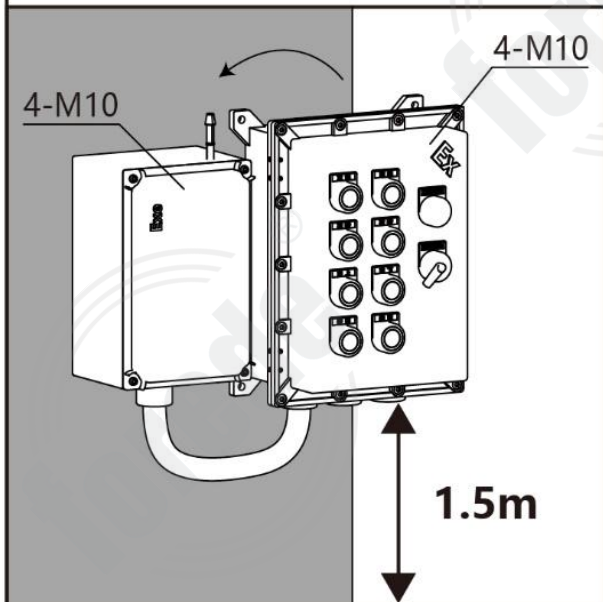

3, Mount the control box on the wall near the fire monitor, the install area should be able to observe the movement of the fire monitor clear, and convenient to evacuate. The control box install height is 1.5 meter from the ground.

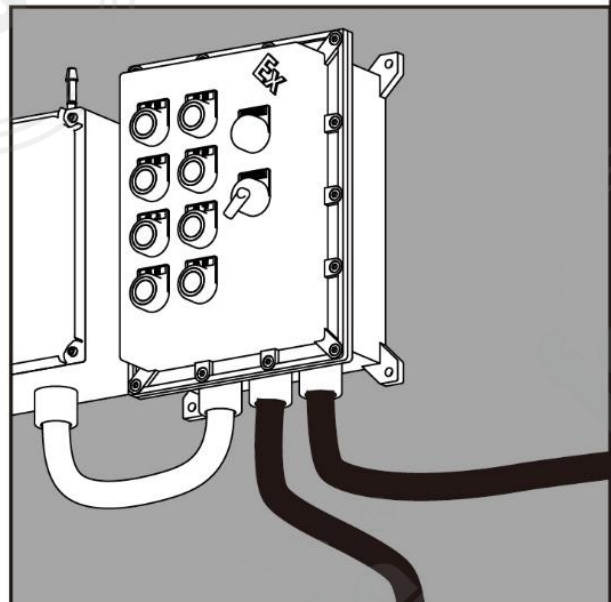

4, Connect in the power supply wire, handle before the electric is shut off.

## OPERATION INTRODUCTION

The Fire Monitor is able to be controlled by Control box and RC transmitter:



- The operation of Control Box as below:

Buttons	Description
Jet	Straight stream
Fog	Fog spray
Left	Turn left the nozzle horizontally
Right	Turn right the nozzle horizontally
Up	Turn up the nozzle vertically
Down	Turn down the nozzle vertically
Open	Open the electrical valve
Close	Close the electrical valve
Power	Indicate the power,light up–power on,light off–power off
Switch	Switch knob,control the power supply,left–on,right–off

PS:Electrical Valve is not standard configuration,all function relate to the Electrical Valve should base on the Electrical Valve is selected in your order.



- The operation of RC transmitter as below:

Buttons	Description
Emergency Stop	The red button,press to disconnect the signal connection with Fire Monitor
Start	The green button,connect the signal connection with Fire Monitor
Jet	Straight stream
Fog	Fog spray
Left	Turn left the nozzle horizontally
Right	Turn right the nozzle horizontally
Up	Turn up the nozzle vertically
Down	Turn down the nozzle vertically
Open	Open the electrical valve (Not standard)
Close	Close the electrical valve (Not standard)

PS:Electrical Valve is not standard configuration,all function relate to the Electrical Valve should base on the Electrical Valve is selected in your order.

## **FIRE MONITOR PARAMETERS**

- Main technical parameters as below:

Model Number	PSKD20EX-BS	PSKD30EX-BS
Working Pressure	8 bar	8 bar
Flow Rate	1200 LPM	1800 LPM
Max. Reach@8bar	≧ 53 m	≧ 60 m
Flow Tolerance	± 8%	
Rotation Horizontally	0~360°	
Elevate Vertically	-90°~+90°	
Horizontal Speed	24°/second	
Vertical Speed	10°/second	
Power Supply	AC 220 V is standard	
Power Consumption	Standby 15W, Max. 115W	
Material	Body&Nozzle:Hard anodized aluminium alloy Gear:Hard anodized aluminium alloy Worm:Stainless steel	
Weight	Approx. 18.5 KGS	
Inlet Flange	2.5 inch (DN65) flange PN16	
Explosion Proof Class	Exd II B T4 Gb	

## OUTLINE DIMENSION

- The dimension of the Fire Monitor as below:

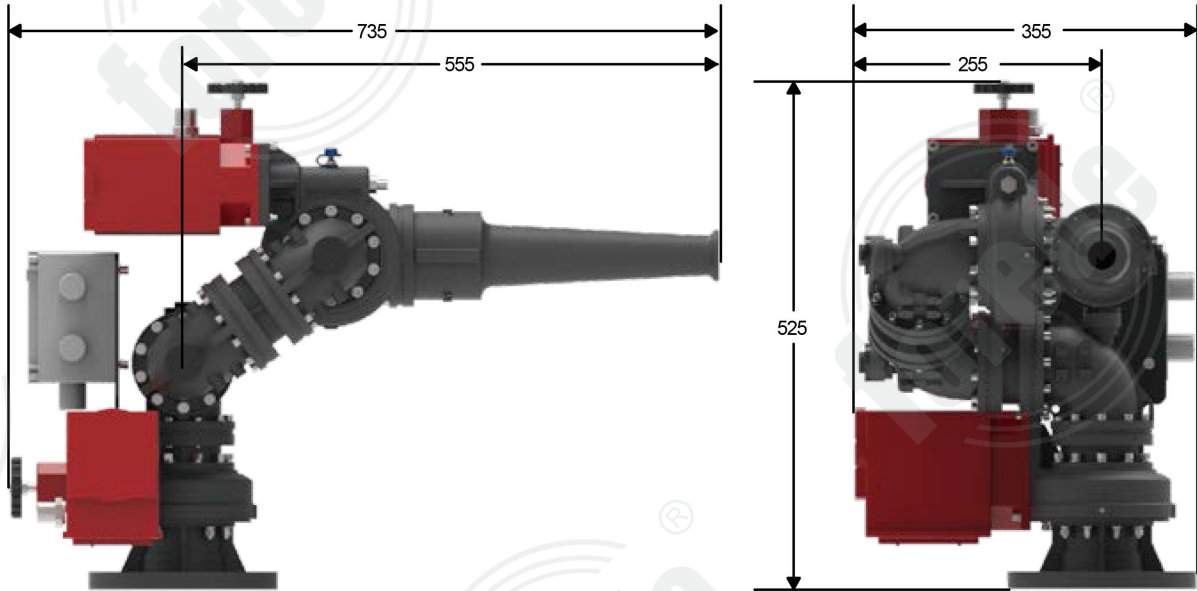

## MOVEMENT ANGLE

- The movement angle of the Fire Monitor as below:

